

8-1-2 MAIN-2

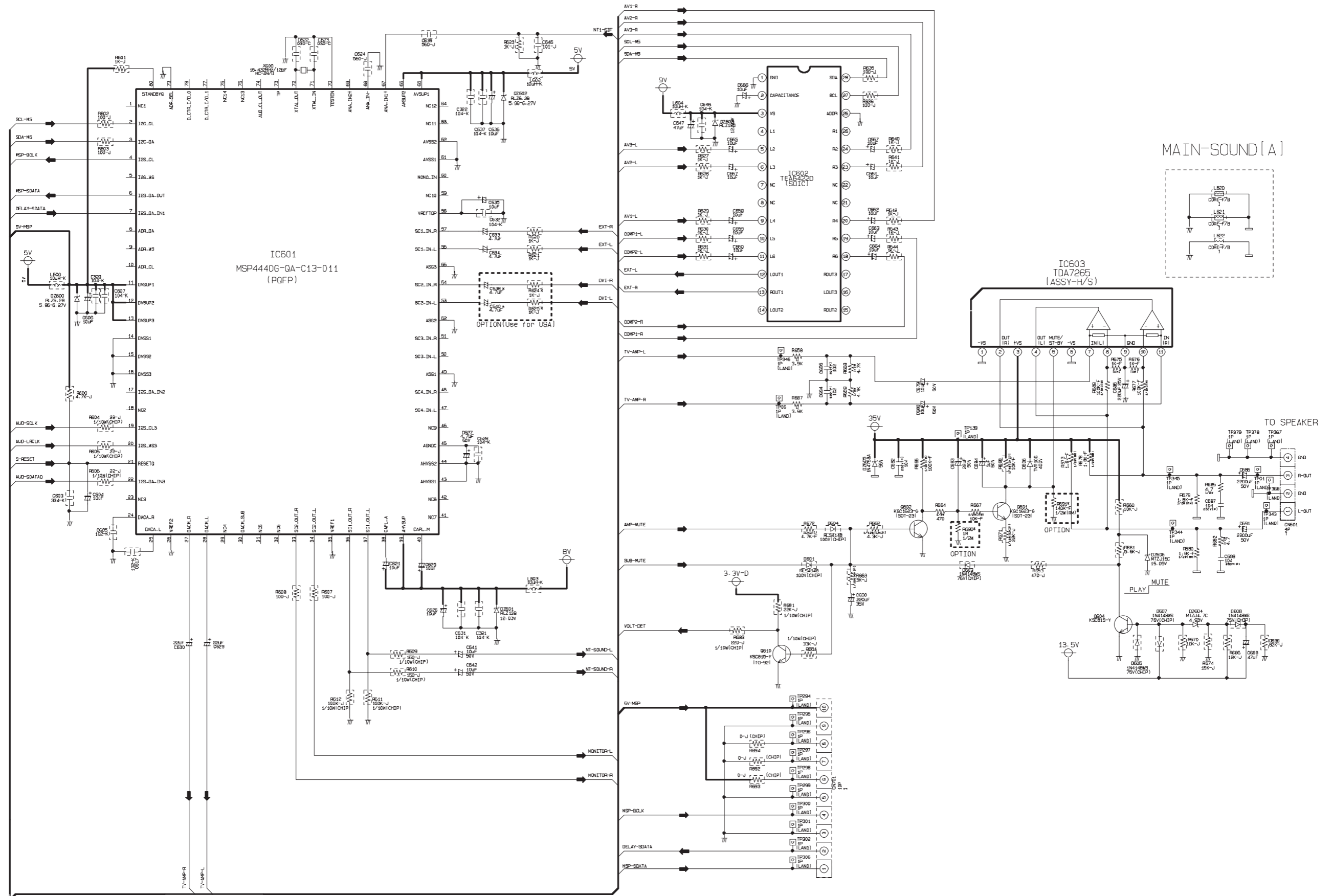

8-1-5 MAIN-5

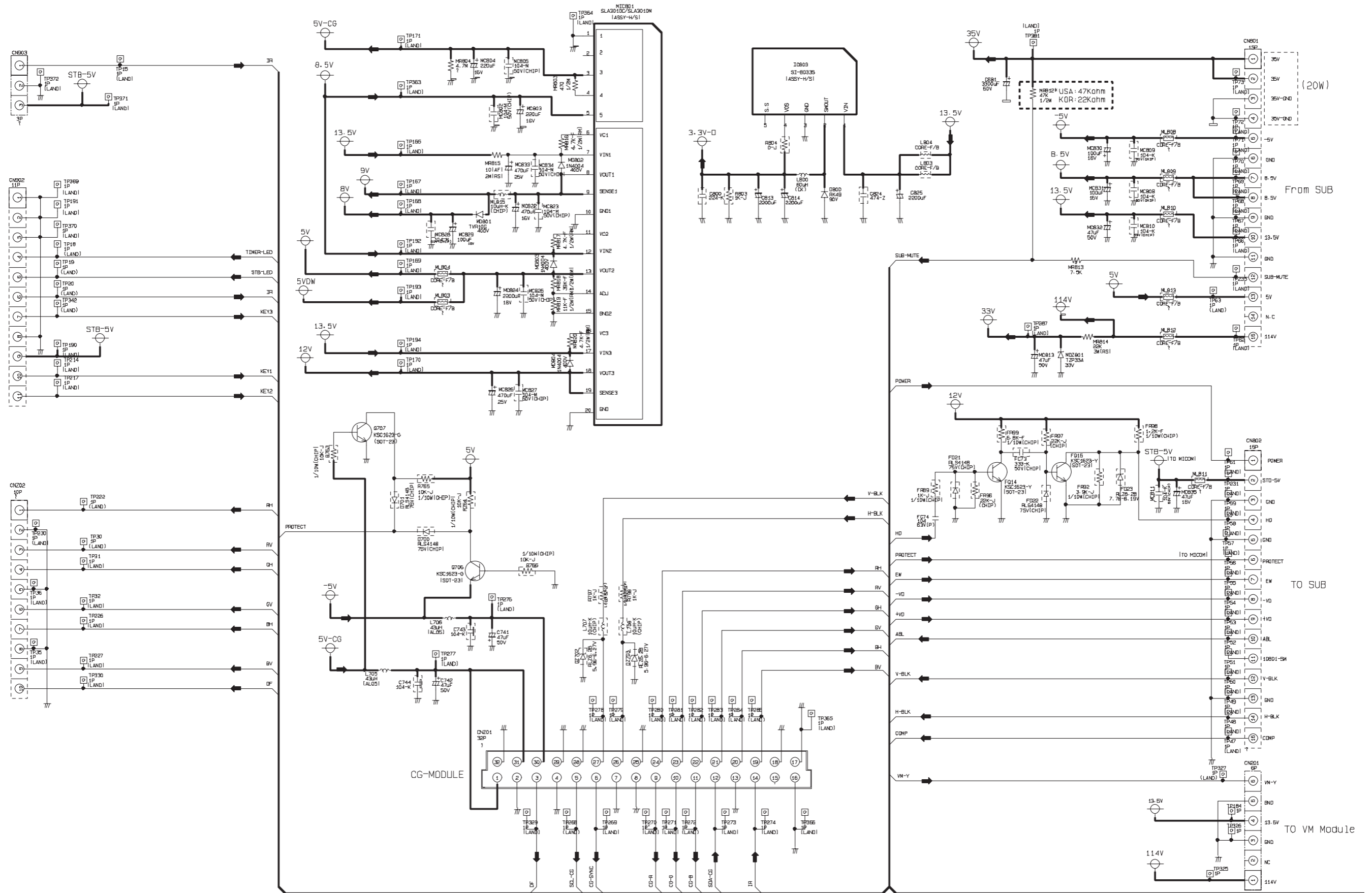

8-2 SUB Board

8-2-1 SUB-1

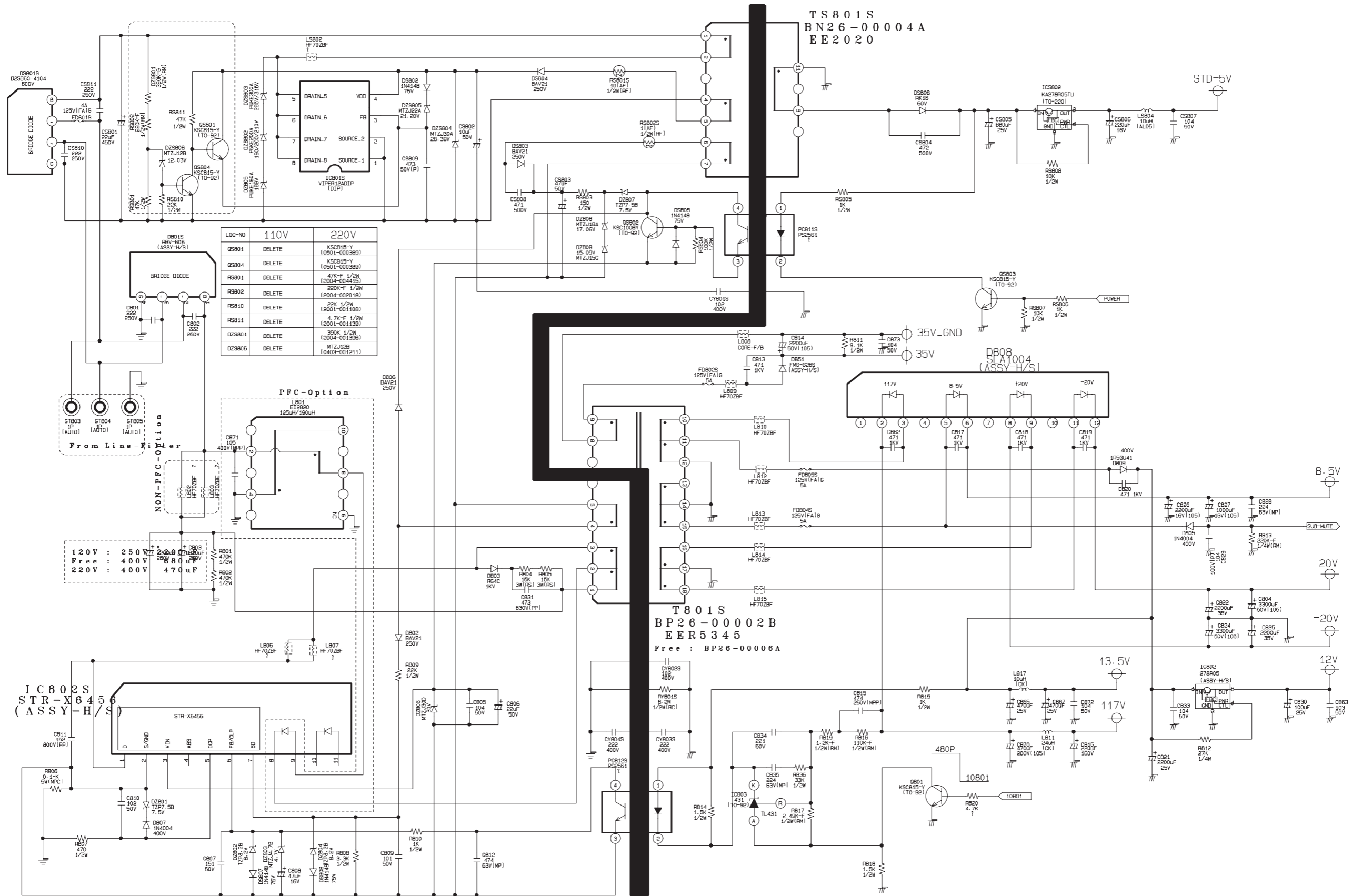

8-2-2 SUB-2

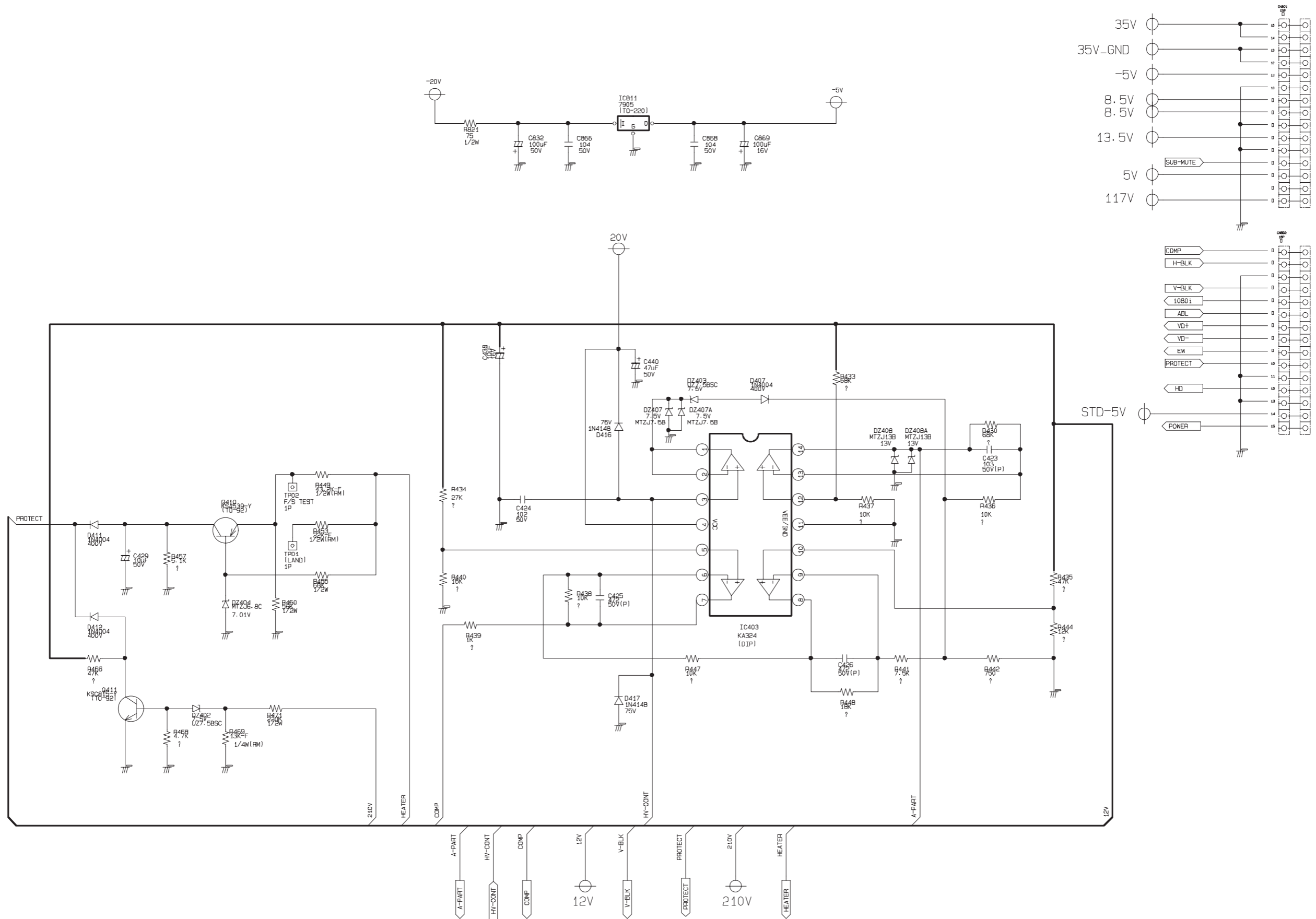

8-2-3 SUB-3

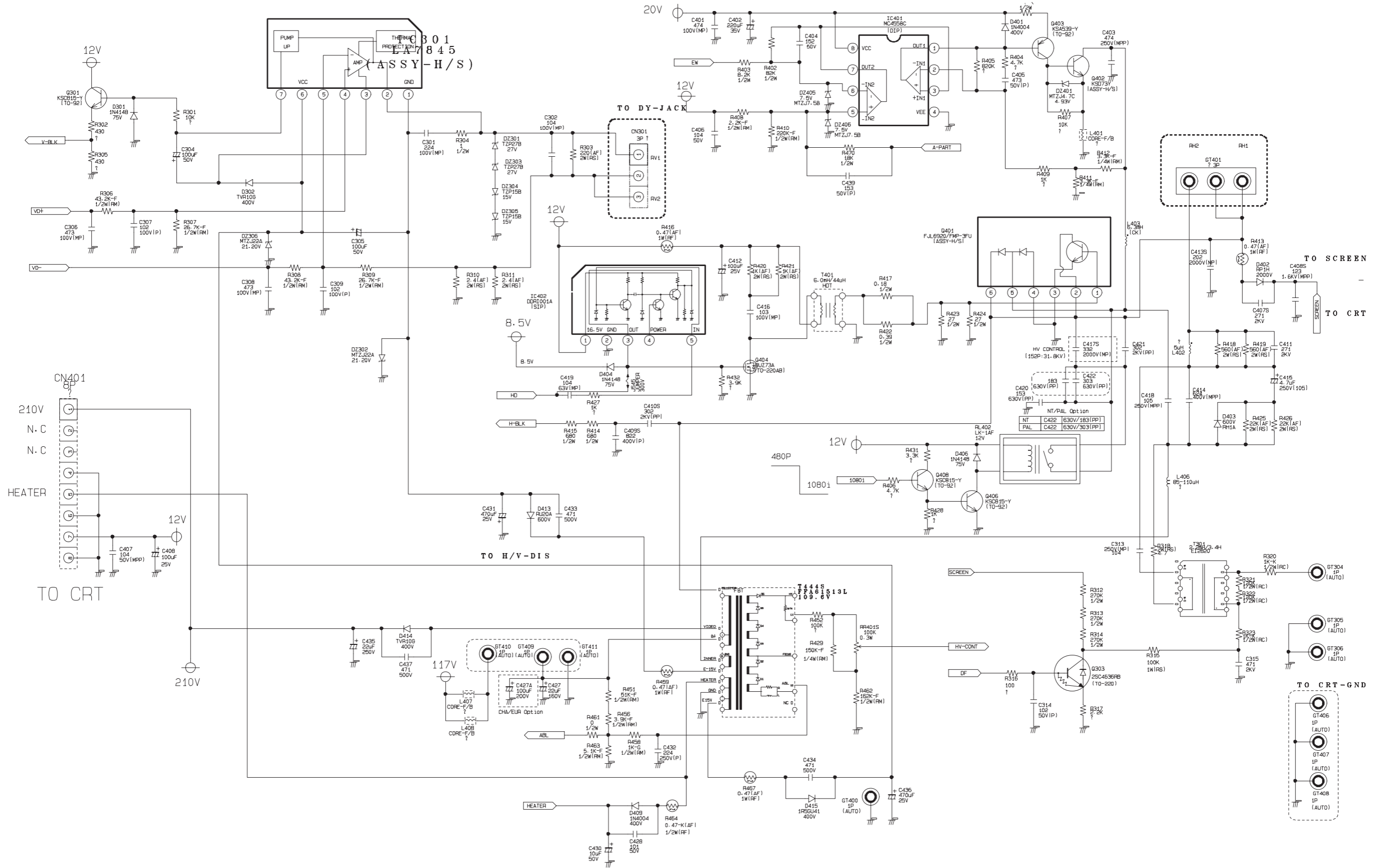

8-2-4 SUB-4

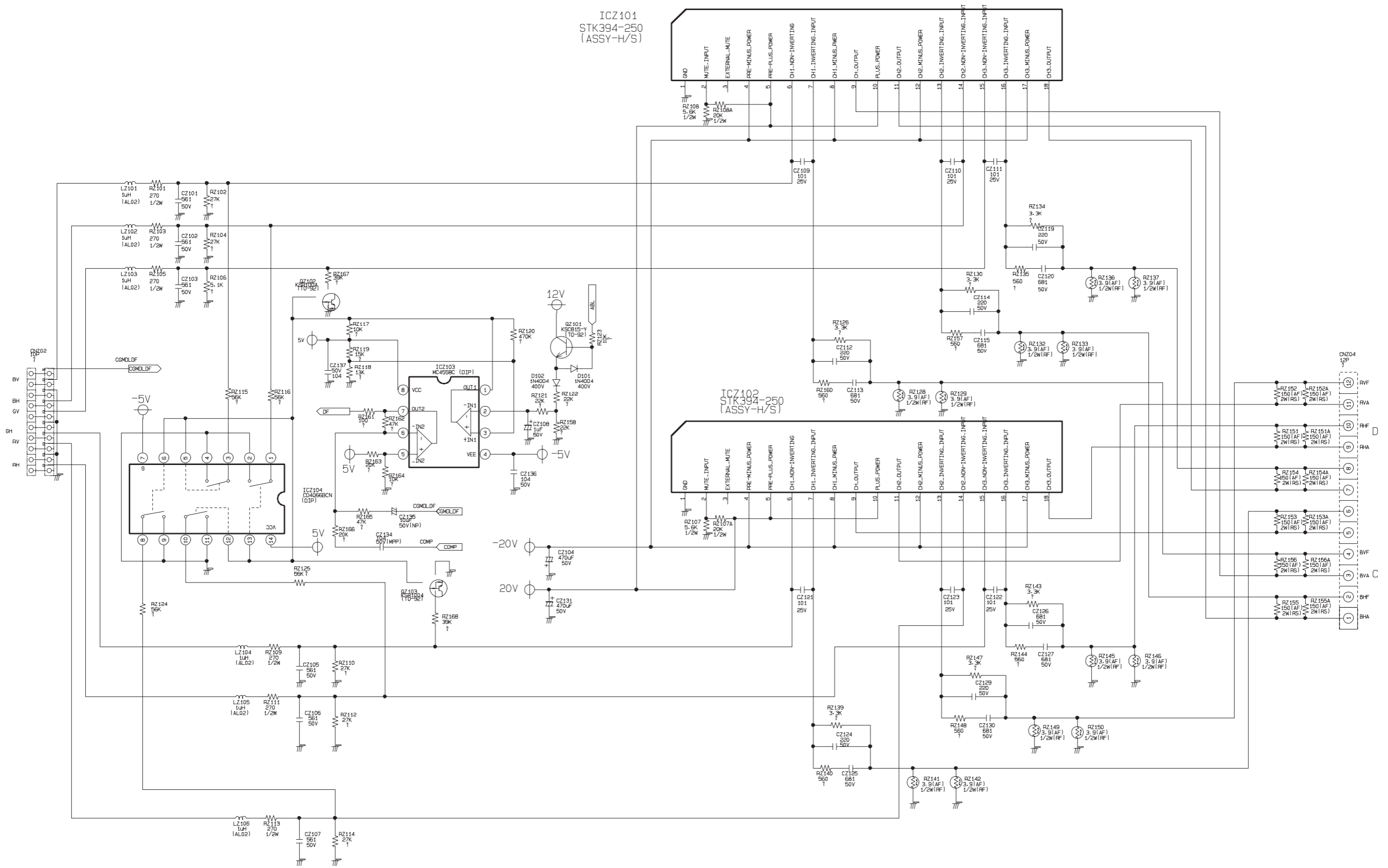

8-3-6 DTV Module-6

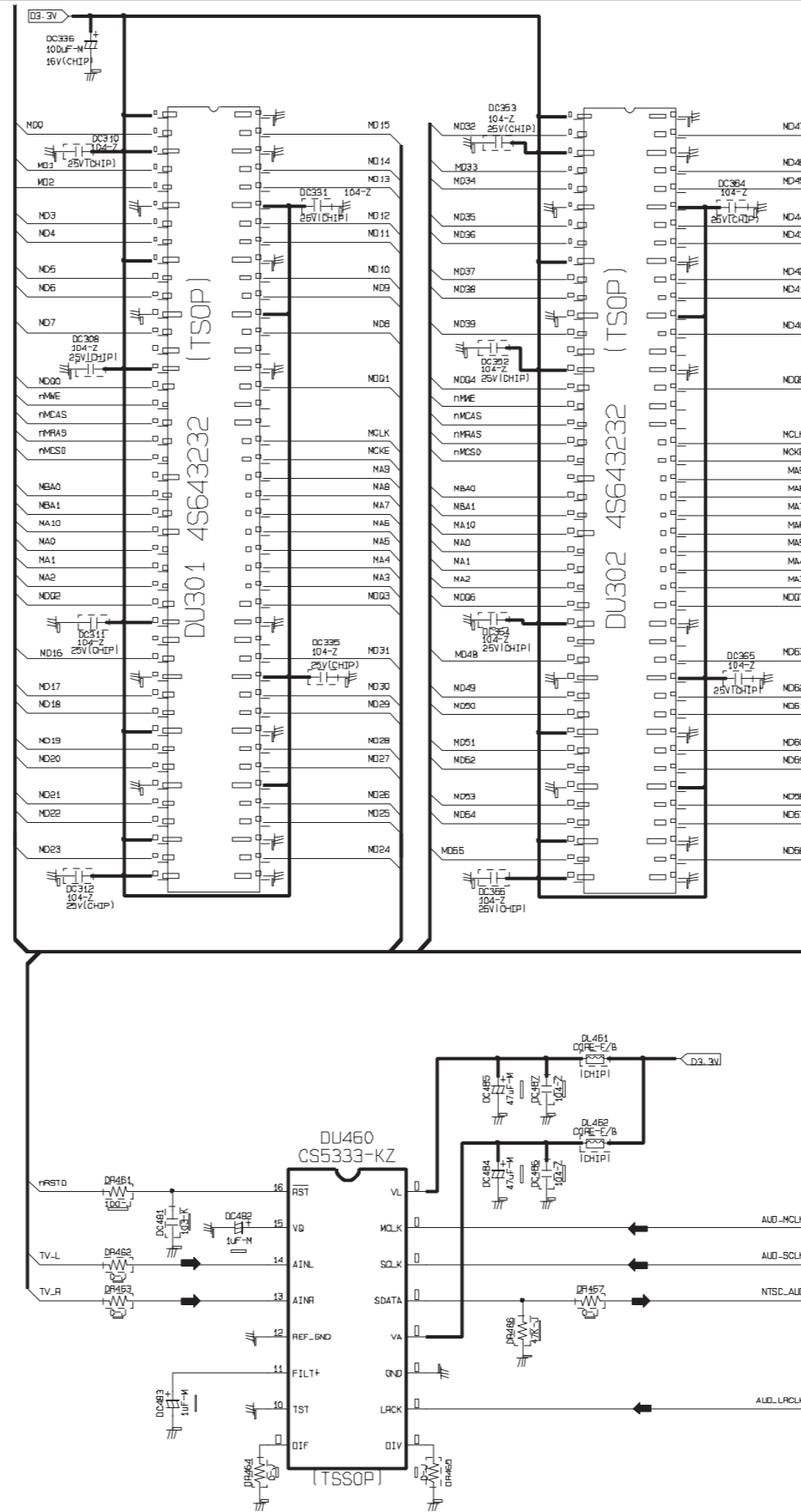

8-3-8 DTV Module-8

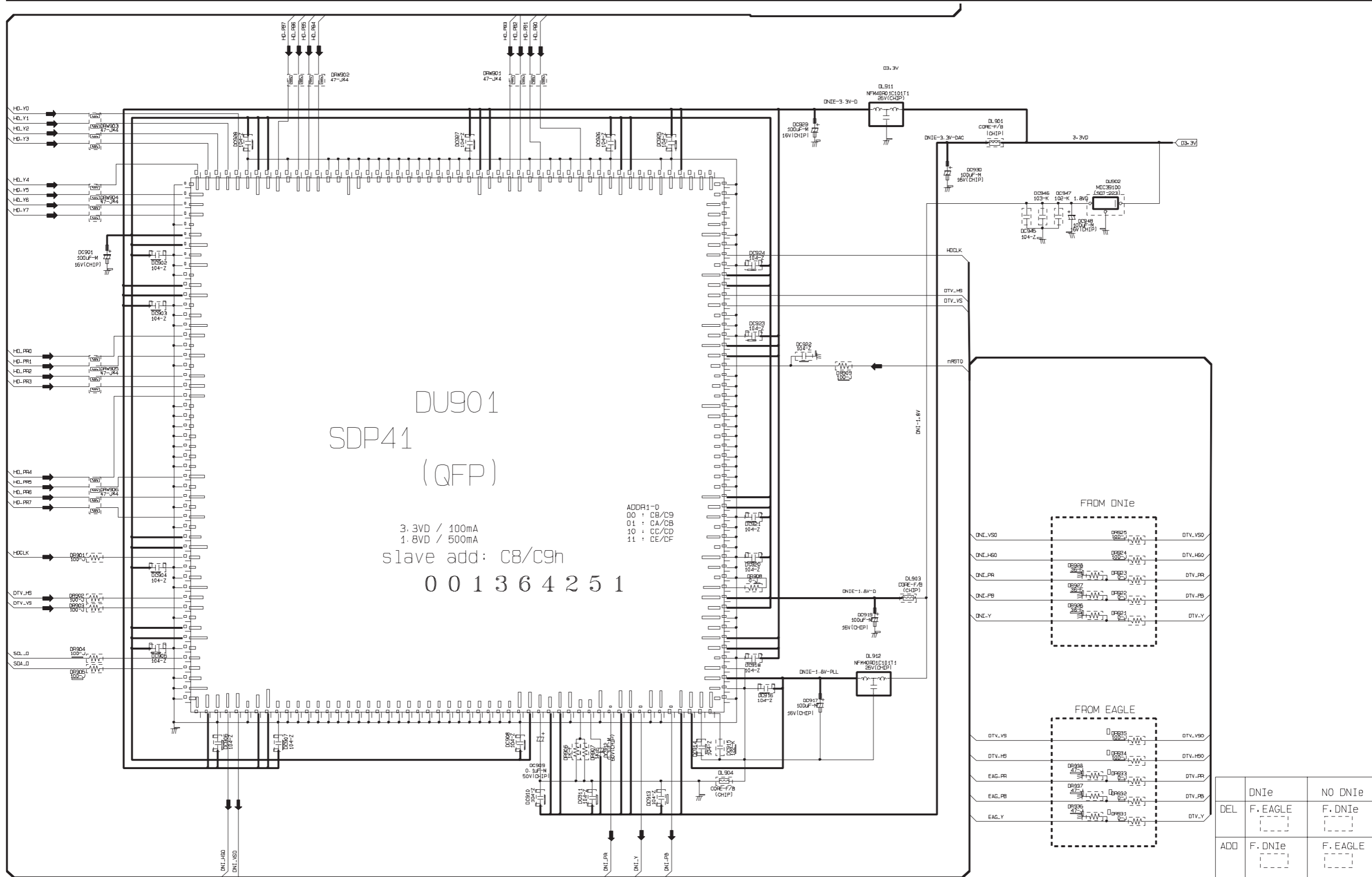

	DNIE	NO DNIE
DEL	F. EAGLE	F. DNIE
ADD	F. DNIE	F. EAGLE

8-4 Convergence_SDC31

8-4-1 Convergence Module-1

This drawing is property of SEC
Use or copy of this drawing without proper permission from the appropriate
technical-document managing department is prohibited.

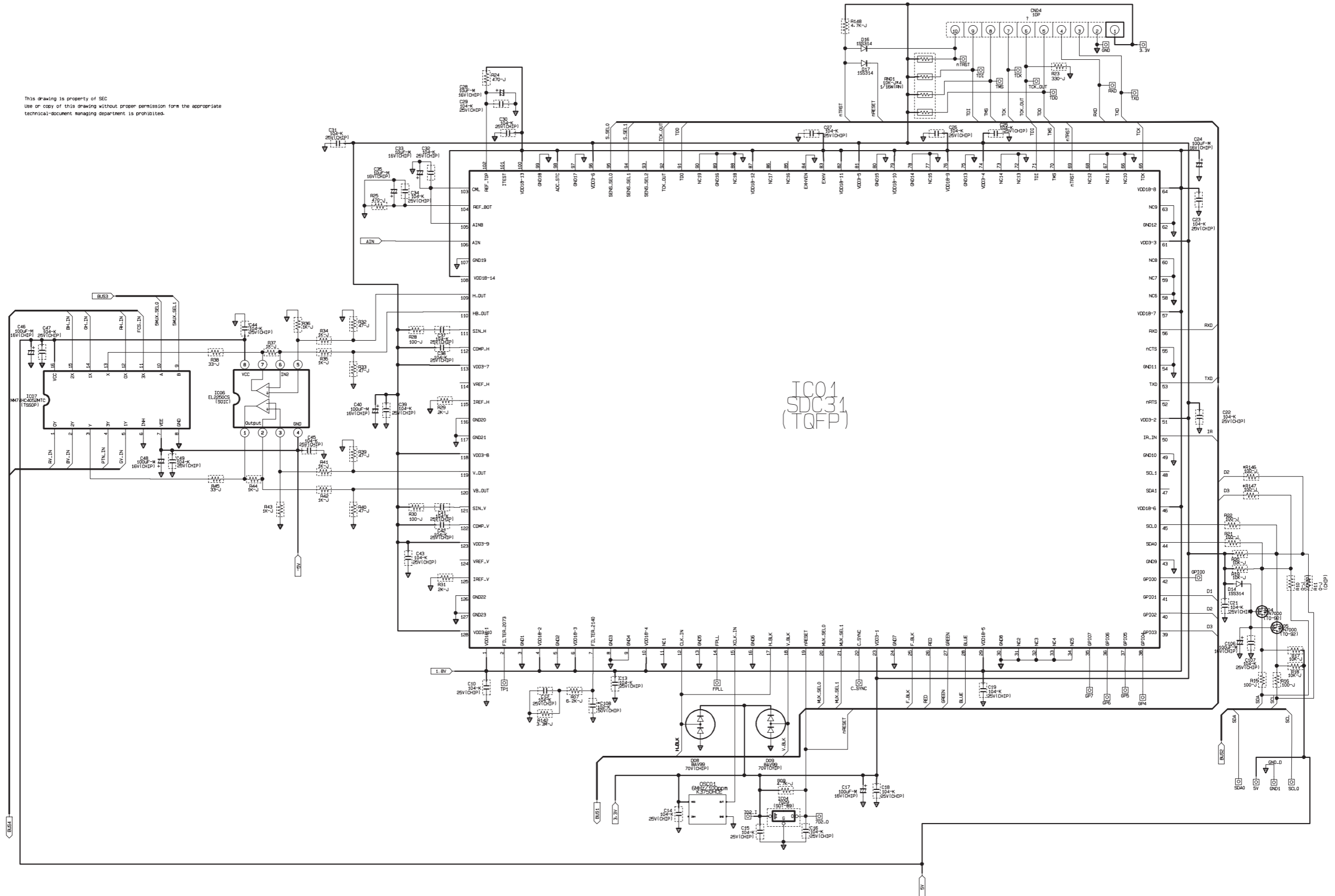

8-4-2 Convergence Module-2

This drawing is property of SEC
Use or copy of this drawing without proper permission from the appropriate
technical-document managing department is prohibited.

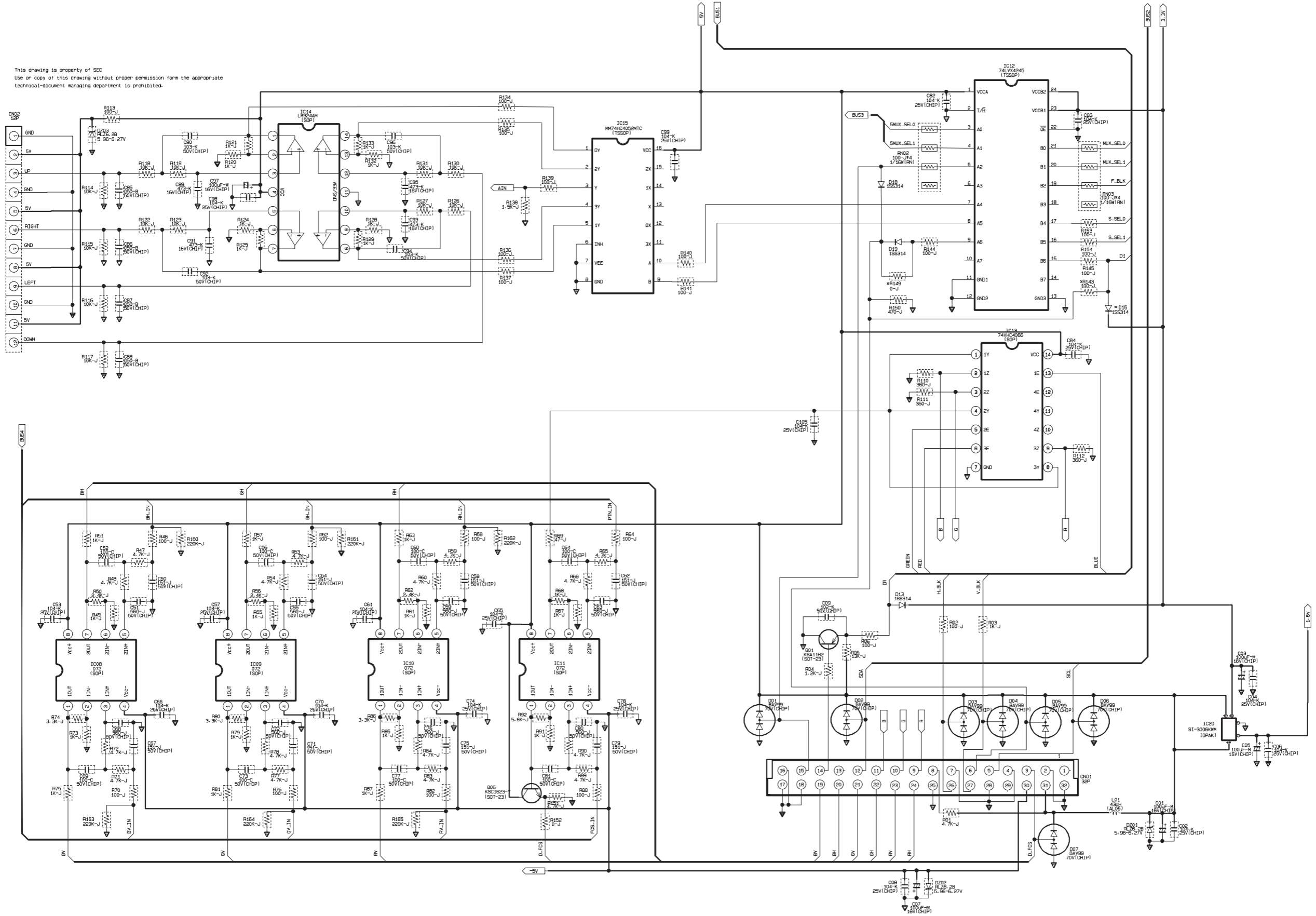

8-5 CRT-PCB

P58A
HCN559W
CRT PCB

This drawing is property of SEC
Use or copy of this drawing without proper permission from the appropriate
technical-document managing department is prohibited.

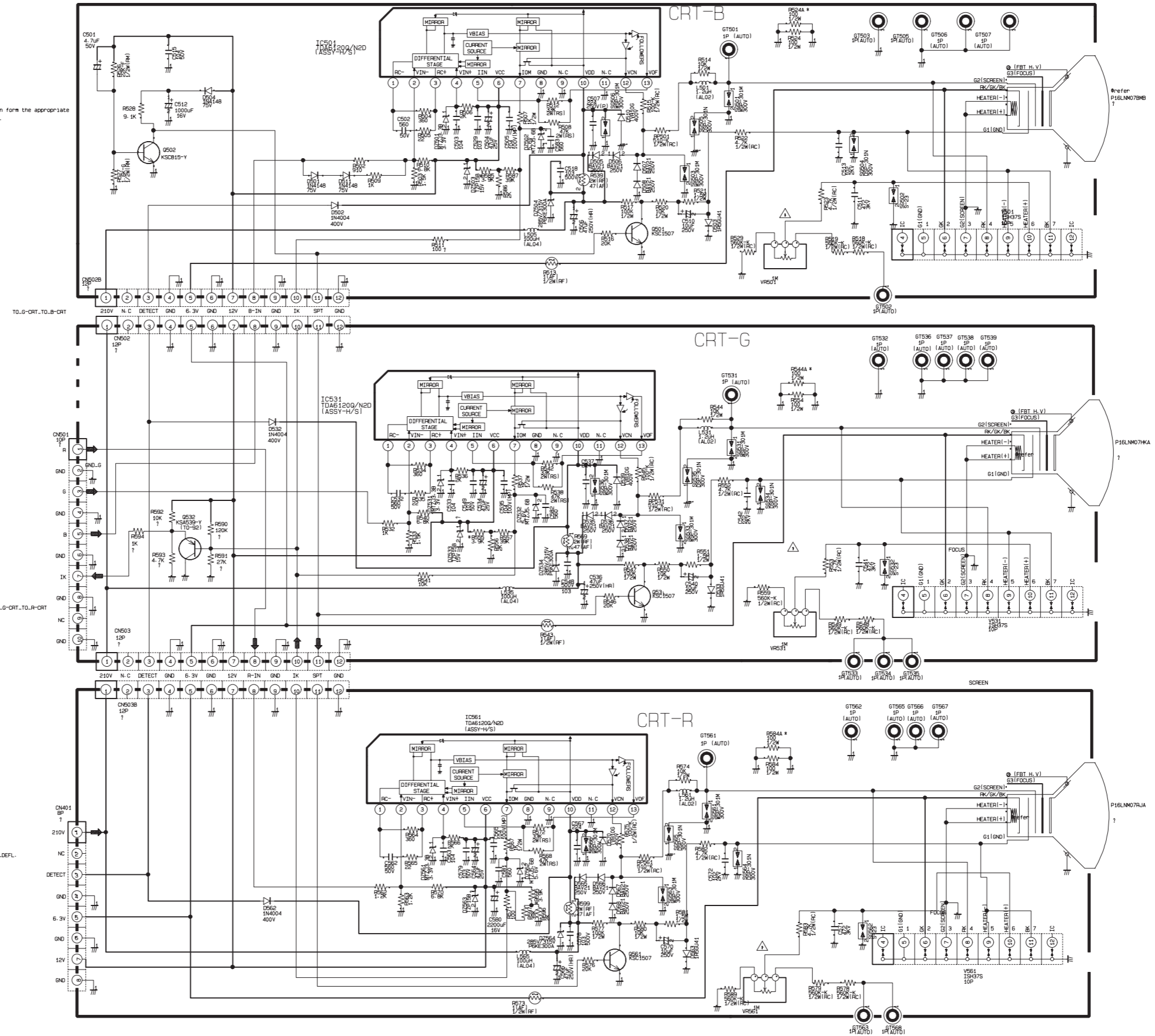

8-6 HV_Module

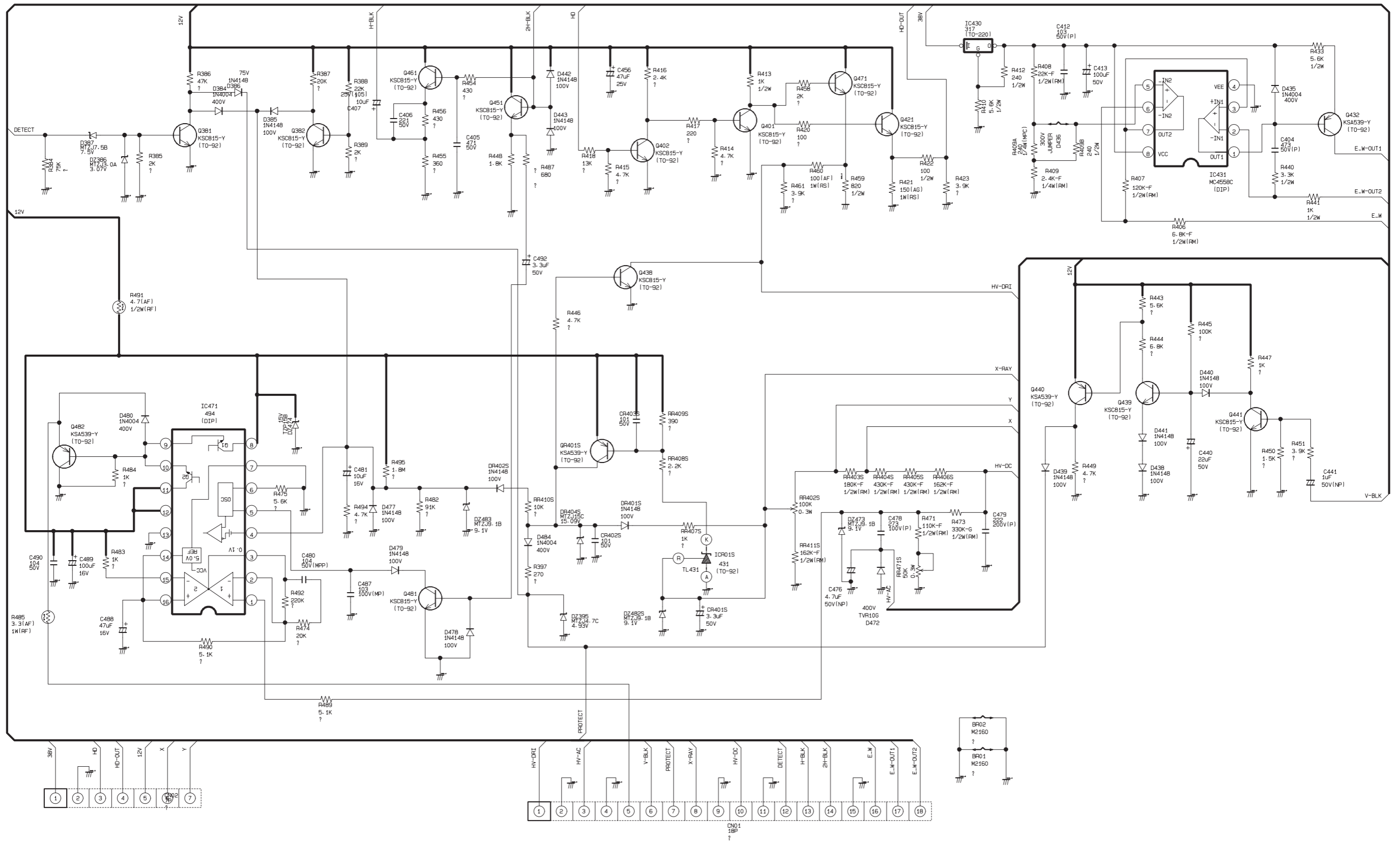

8-7 VM_Module

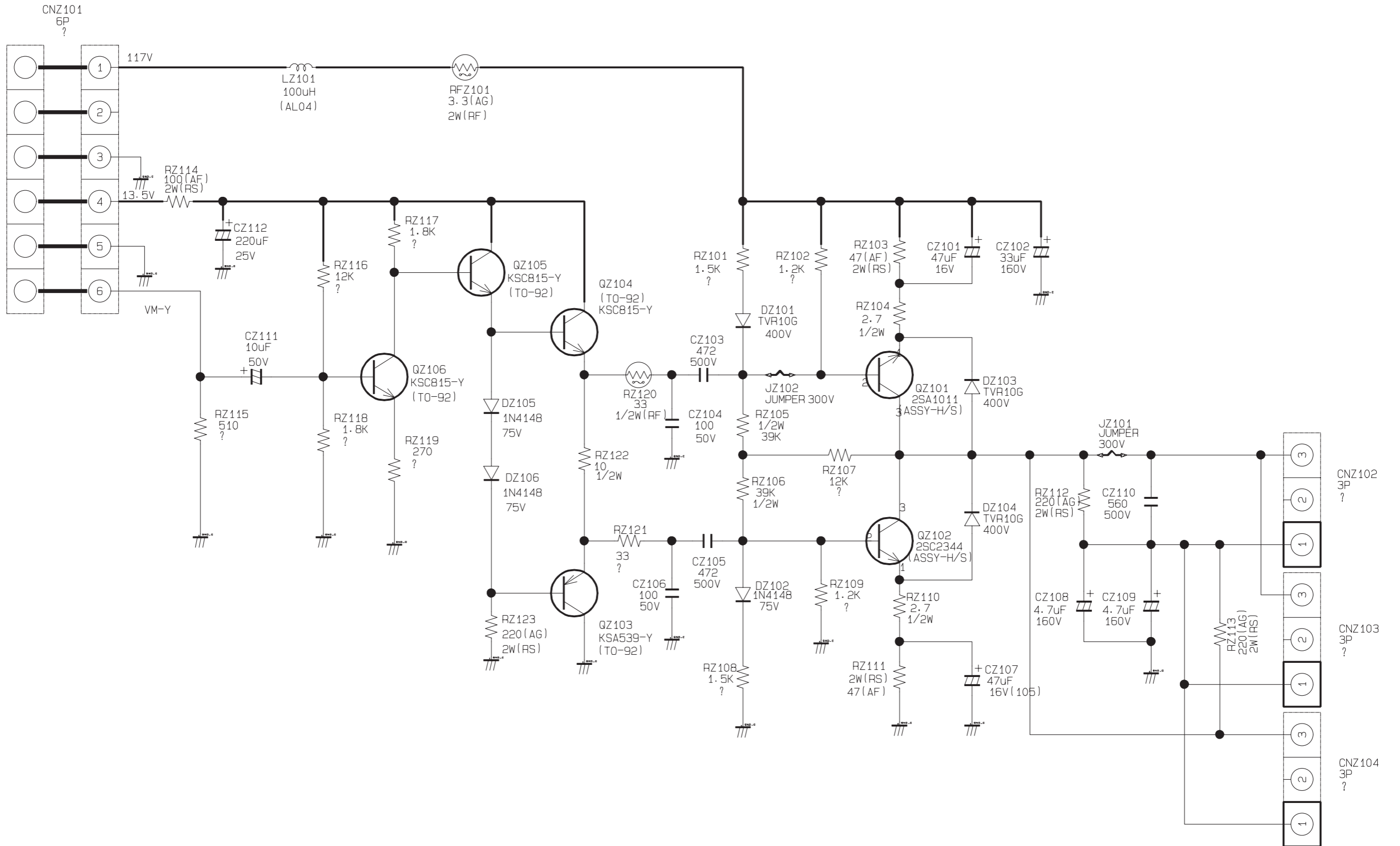

8-8 PWR_Control

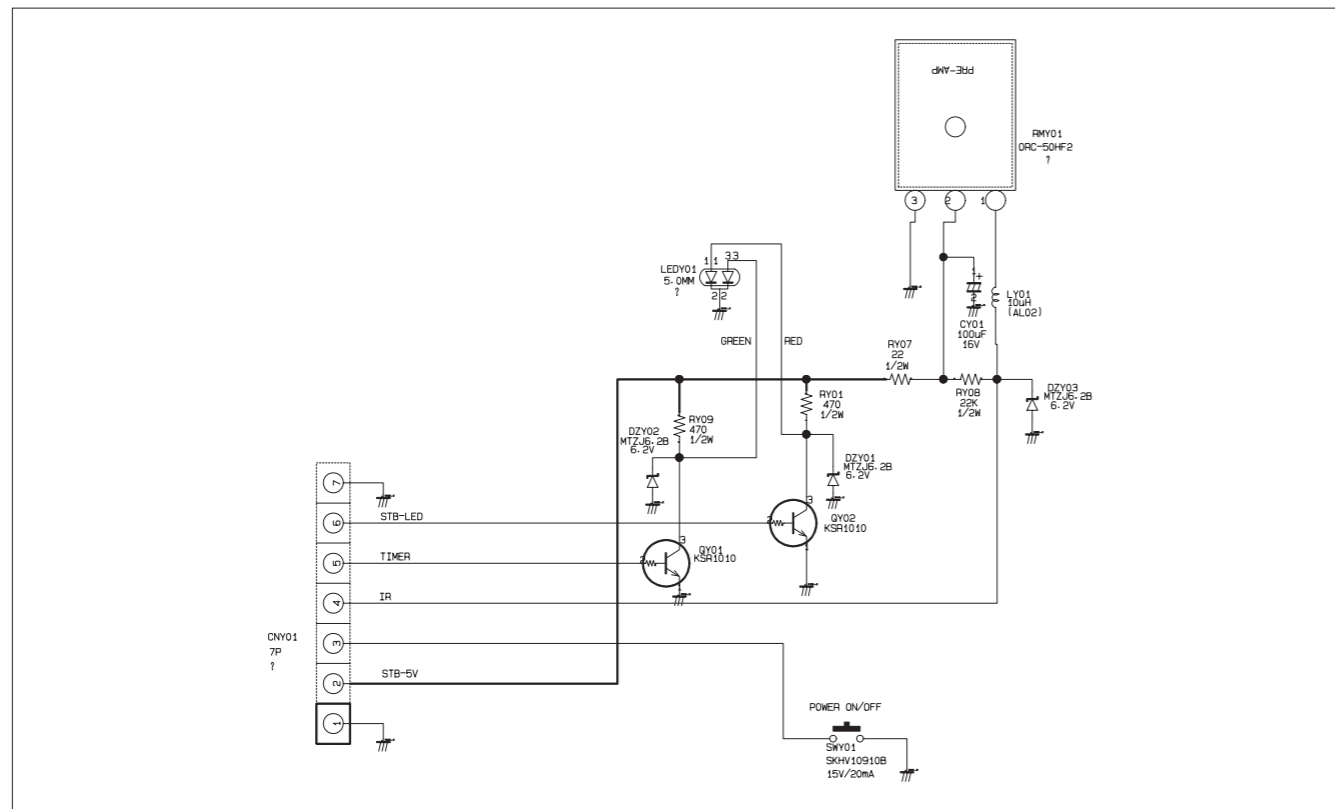

8-9 Key Control

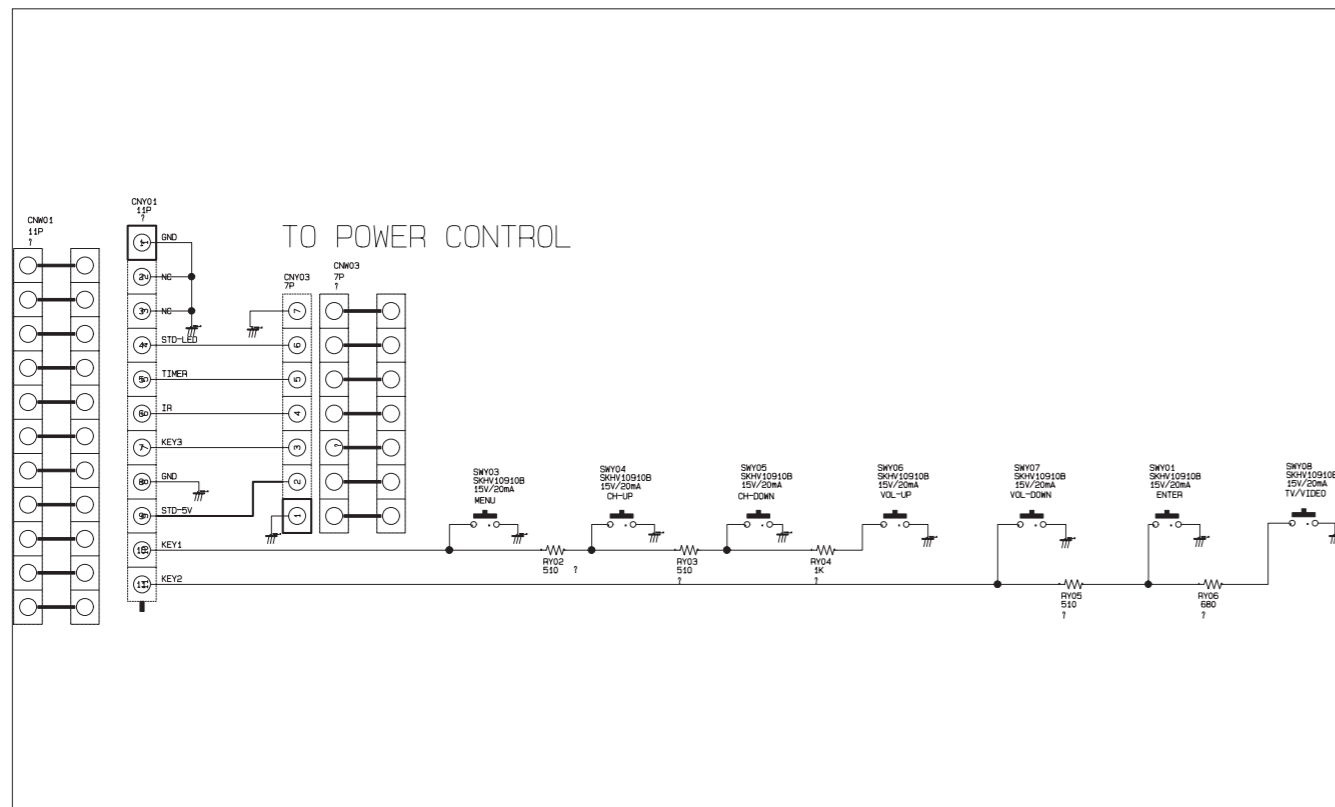

8-10 Side-AV

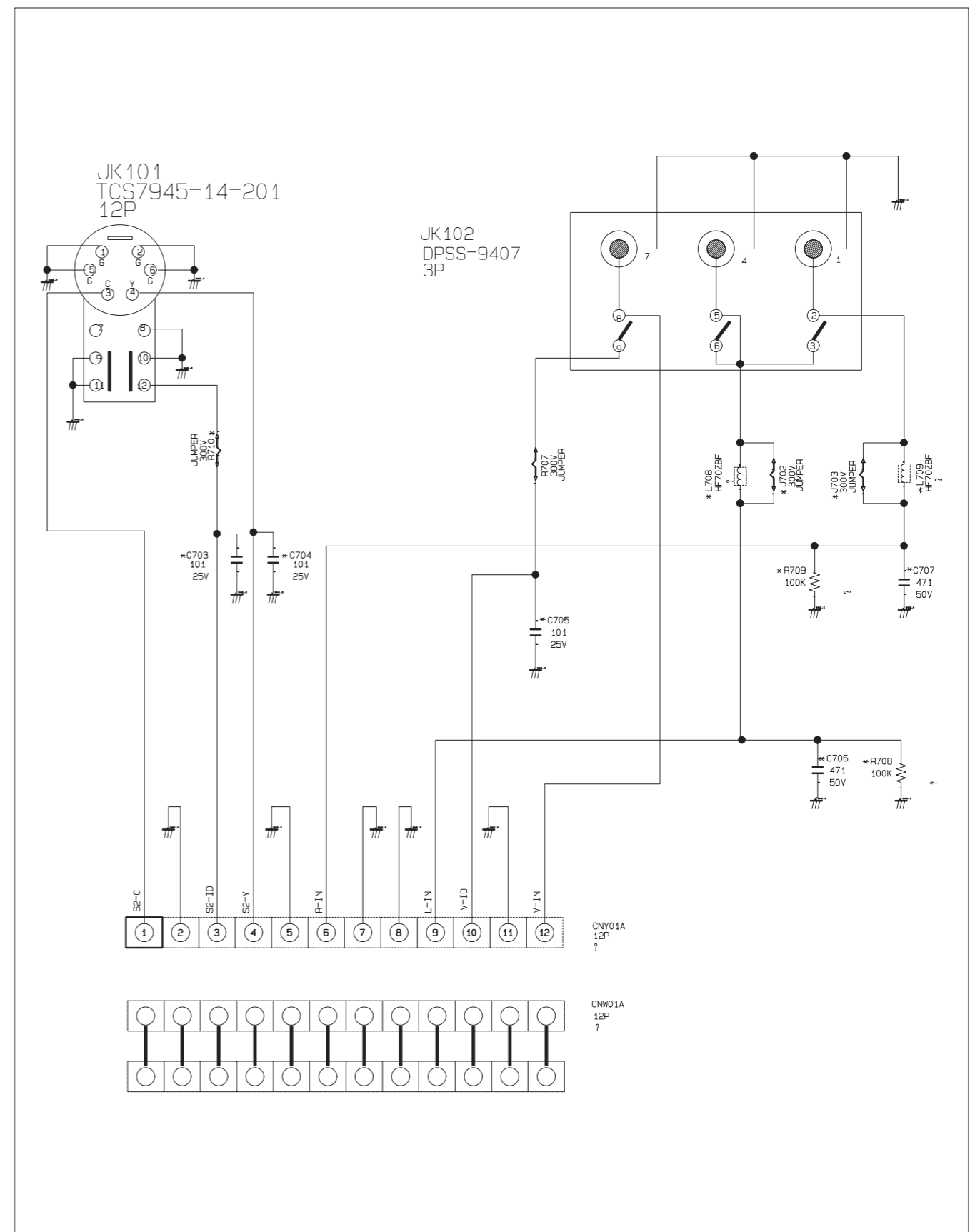

8-11 Sensor

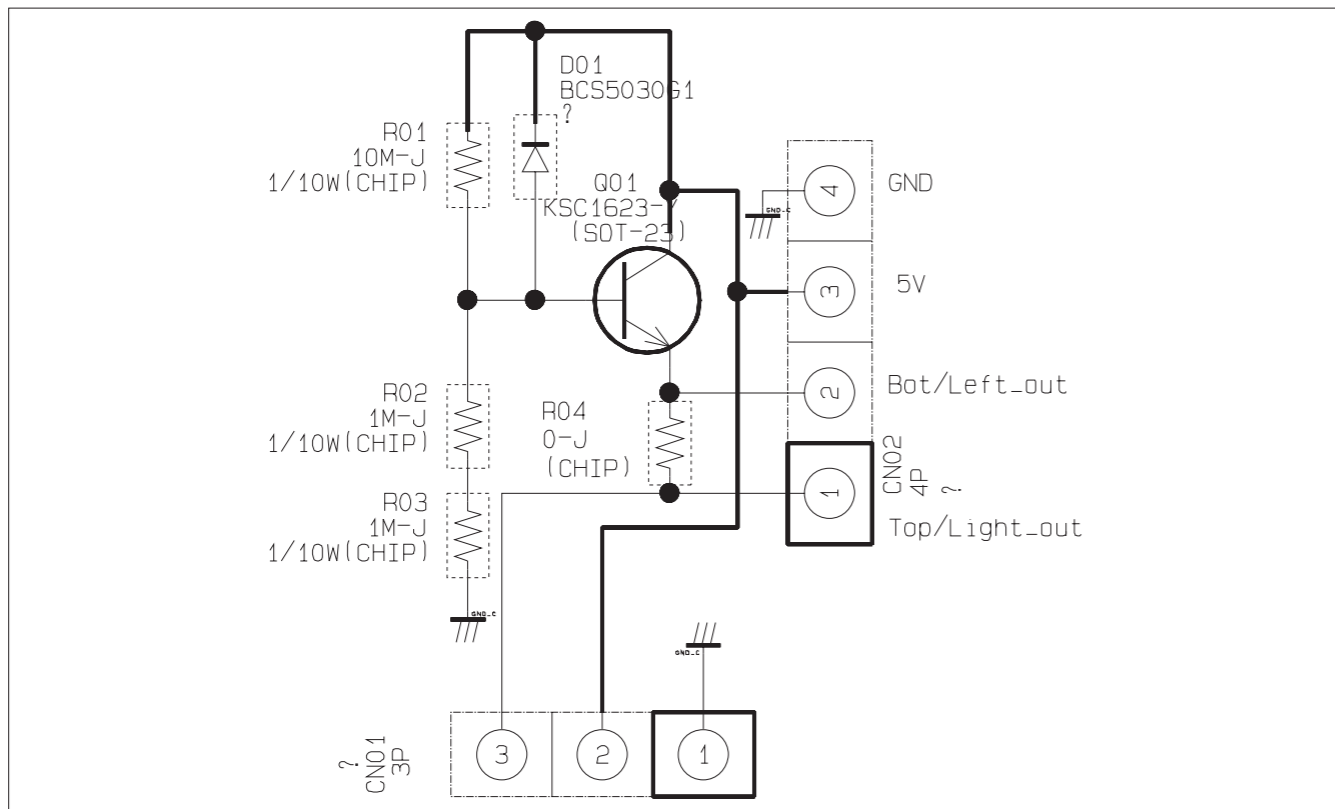

8-13 DY-JACK

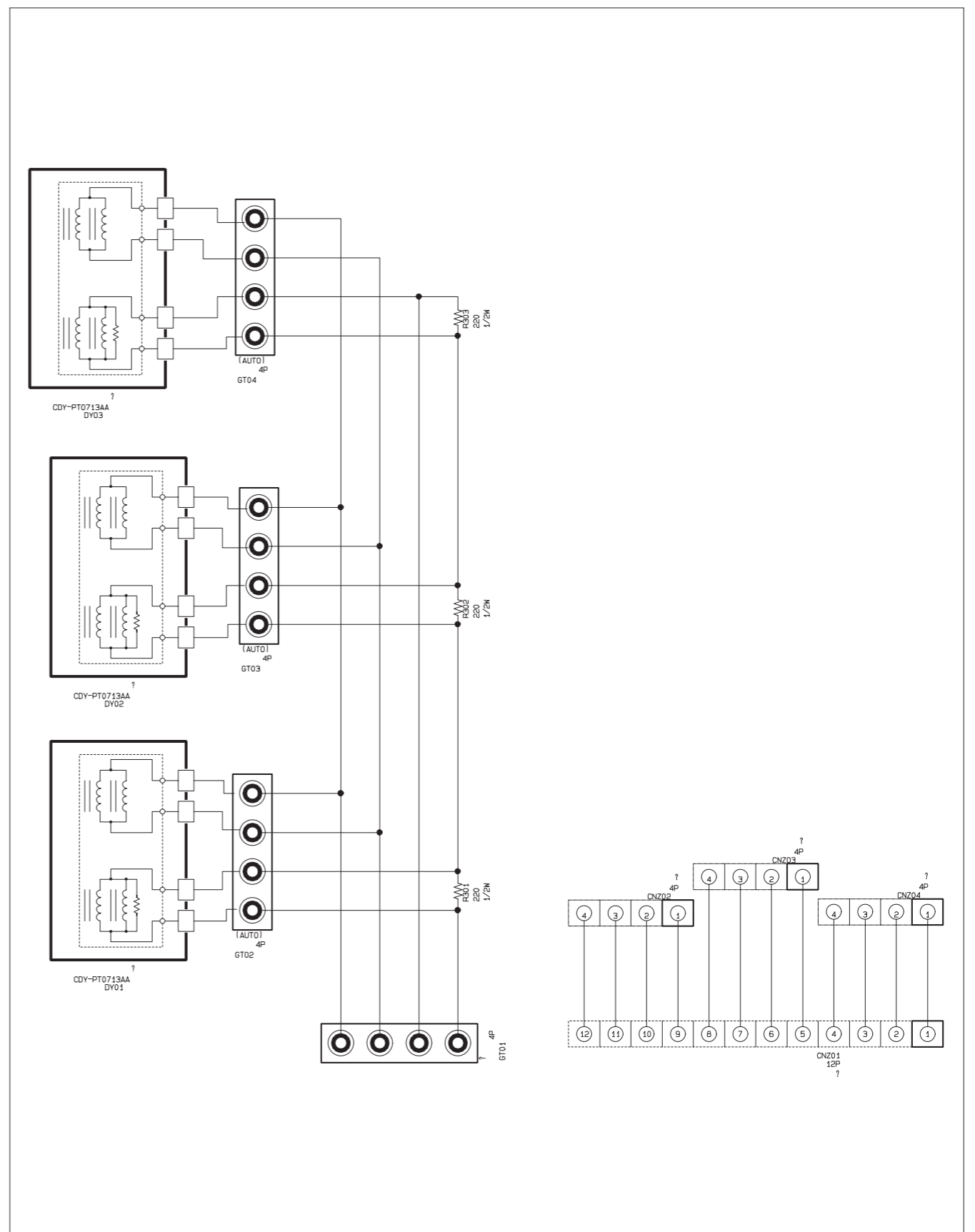

8-12 Line-Filter

